

**Drive<sup>IT</sup>**  
**Low Voltage**  
**AC Drives**









**ACS 400V Instructions**  
**Supplement for ACS 400**  
**User's Manual**



[efesotomasyon.com](http://efesotomasyon.com)

---

## Safety

-  **Warning!** Only a competent electrician may install the ACS 400V.
-  **Warning!** Dangerous voltages are present when mains supply is connected. Wait at least 5 minutes after disconnecting the supply before removing the cover. Measure the voltage at DC terminals ( $U_{c+}$ ,  $U_c$ ) before servicing the unit. See ACS 400 User's Manual Reference Section **E**.
-  **Warning!** Even when the motor is stopped there are dangerous voltages present at Power Circuit terminals U1, V1, W1 and U2, V2, W2 and  $U_{c+}$ ,  $U_c$ .
-  **Warning!** Even when the ACS 400V is powered down, there may be dangerous external voltages at relay terminals RO1A, RO1B, RO1C, RO2A, RO2B, RO2C.
-  **Warning!** Never attempt to repair a broken unit; contact the supplier.
-  **Warning!** The ACS 400V will start up automatically after an input voltage interruption if the external run command is on.
-  **Warning!** When the control terminals of two or more ACS100/140/160/400/400V units are connected in parallel, the auxiliary voltage for these control connections must be taken from a single source which can either be one of the units or an external supply.
-  **Warning!** The heat sink may reach a high temperature (see ACS 400 User's Manual Reference Section **S**, Table 11).
-  **Warning!** The ACS 400V unit with a RFI filter cannot be used in distribution networks isolated from earth (floating networks, IT networks). Otherwise the net will be connected with the earth potential via filter capacitors.

If the drive is connected to IT network, grounding screws and the RFI filter must be removed. Refer to ACS 400 User's Manual Reference section I Floating Network for instructions on screw locations.

**Note!** For more technical information refer to ACS 400 User's Manual or contact your local ABB supplier.



This instruction is a supplement to the ACS 400 User's Manual which is delivered with the frequency converter. This instruction describes the unique features of ACS 400V which make it especially suitable for HVAC (heating, ventilation and air conditioning) applications. The software of this product has been developed in co-operation with Fläkt Woods Group. In case of other technical information, a reference to the ACS 400 User's Manual is made.

## Table of Contents

<b>Safety .....</b>	<b>3</b>
<b>Installing the ACS 400V .....</b>	<b>7</b>
<b>Controlling the ACS 400V .....</b>	<b>10</b>
<b>I/O Configuration .....</b>	<b>11</b>
<b>Alternative ACS 400V Operation Modes (Hardwire Connections) ..</b>	<b>12</b>
Start / Stop and External Control Signal 0-10 V .....	12
Start / Stop with 1 Constant Speed .....	13
Start / Stop with 2 Constant Speeds .....	14
PID Control with 1 Setpoint .....	15
PID Control with 2 Setpoints .....	16
<b>Operating with ACS-PAN-A Control Panel .....</b>	<b>17</b>
Control Modes .....	17
Actual Values in Output Display .....	18
Menu Structure .....	18
Setting Parameter Value .....	18
Changing Between Basic and Full Parameter Set .....	19
Diagnostic displays .....	19
Resetting the Drive from the Control Panel .....	19
LED Indicators .....	19
<b>Parameterising ACS 400V .....</b>	<b>20</b>
<b>Appendix 1: .....</b>	<b>22</b>
Electro Magnetic Compatibility EMC .....	22



## Installing the ACS 400V

Mount the ACS 400V with the RFI filter on the wall. With ACS 400V for powers 15 kW and more (frame size R3 and R4) the RFI filter can be mounted either below or next to the drive.

Figure 1 ACS 400V Frame sizes R1 and R2 (3.0 - 11 kW).

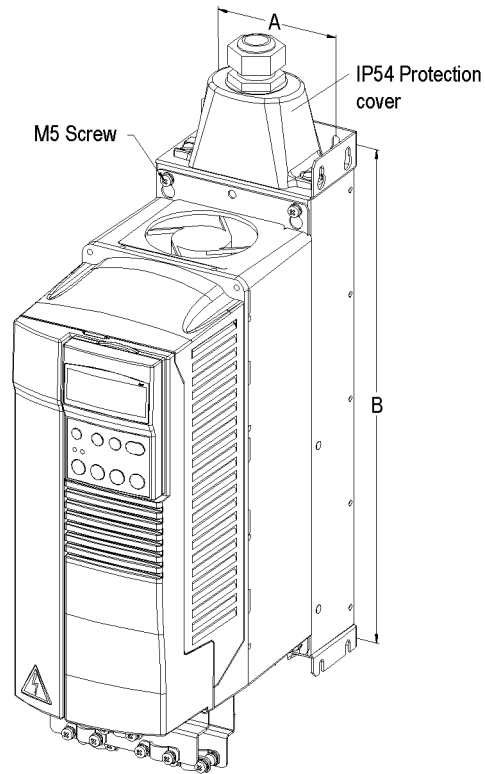

[efesotomasyon.com](http://efesotomasyon.com)

Drive Type ACS401-	RFI Filter Type	A (mm)	B (mm)	C (mm)	D (mm)	E (mm)
V004 - V006	ACS400-IF11-3	90	361.5	35	98	318
V009 - V011	ACS400-IF21-3	90	461	35	98	417

Figure 2 ACS 400V frame sizes R3 and R4 (15 - 37 kW).

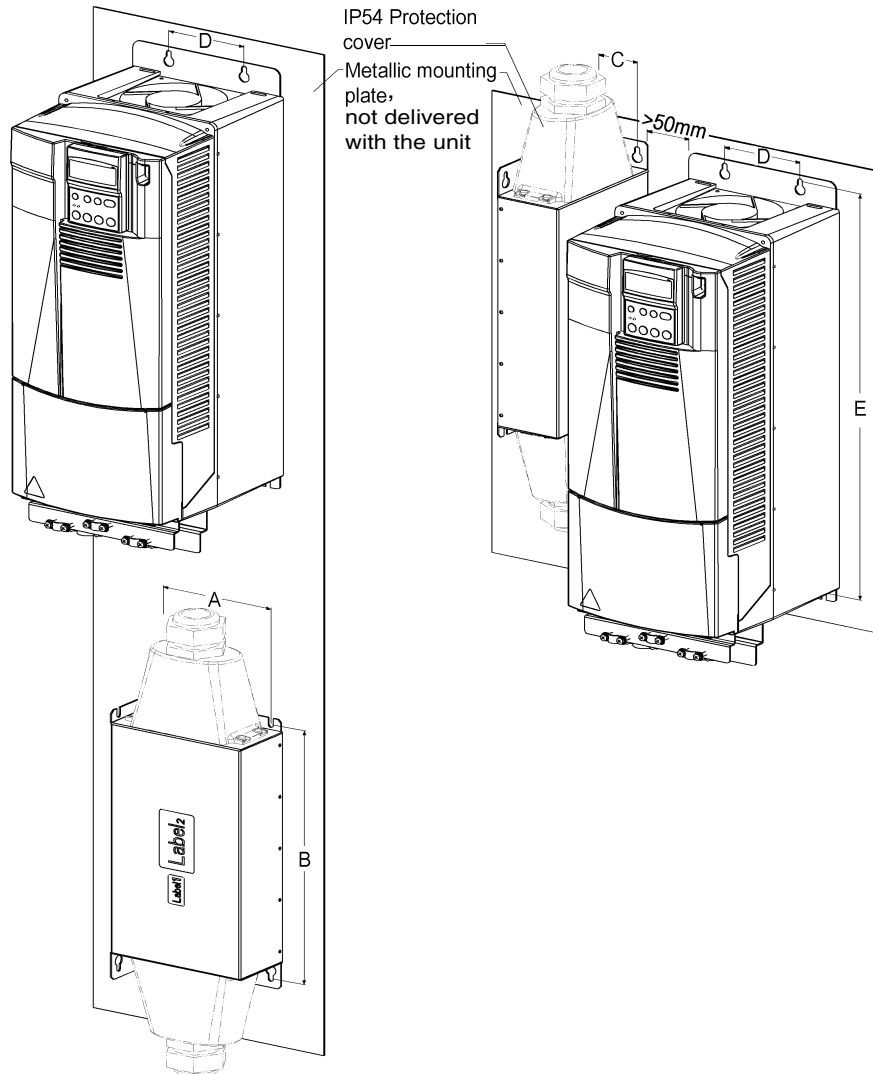

Drive Type ACS401-	RFI Filter Type	A (mm)	B (mm)	C (mm)	D (mm)	E (mm)
V016 - V020	ACS400-IF31-3	140	230	50	160	528
V025 - V041	ACS400-IF41-3	160	280	50	160	619

Connect the RFI filter to the supply (line) side of the drive. See ACS 400V and corresponding RFI filter mounting dimensions from the table below.

Mount the IP54 protection cover(s) to the RFI filter end(s) to get IP54 protection class for the EMC filter. The frequency converter unit protection class depends on the ordered type. In frame size R1 and R2 one IP54 filter cover is required on the supply cable entry end of the filter. In frame size R3 and R4 two IP54 filter covers are required, one on each end. See the following figures for mounting and cabling.

Figure 3 Cabling ACS 400V with IP54 protection cover.

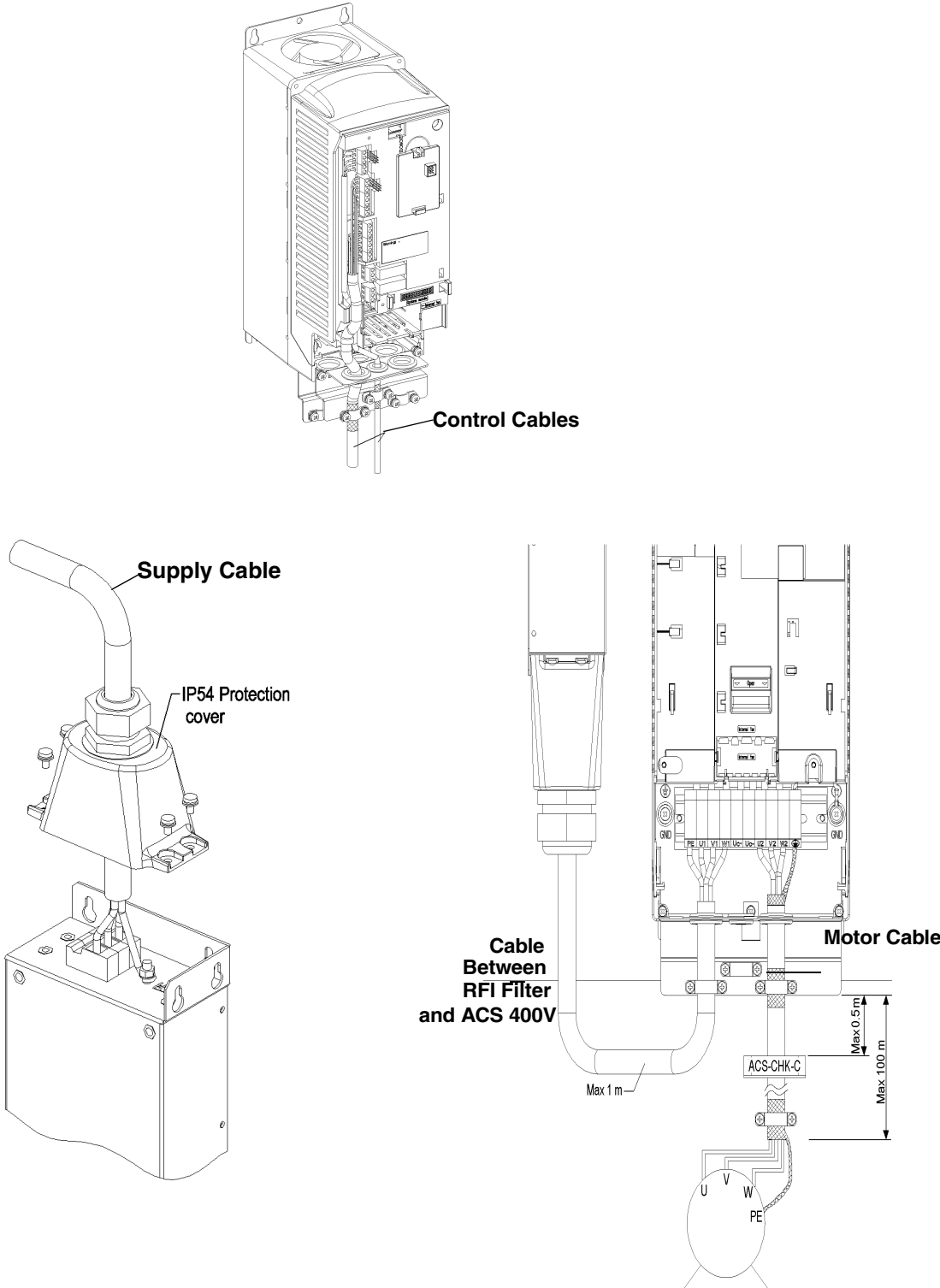

**Note!** ACS-CHK-C is needed and supplied only with ACS400-IF41-3 filter.

# Controlling the ACS 400V

The ACS400V can be used from external or local control locations.

## External control possibilities

1. Control from I/O: Depending on the I/O connections ACS 400V can be used in alternative operation modes. These modes, which are explained later in more detail, are designed to meet the requirements of several HVAC applications:

- Speed Control via External Control Signal 0-10 V, see page 12
- Start / Stop with 1 Constant Speed, see page 13
- Start / Stop with 2 Constant Speeds, see page 14
- PID Control with 1 Setpoint, see page 15
- PID Control with 2 Setpoints, see page 16

2. Control via Fieldbus: Modbus protocol is as default fieldbus in ACS 400V. In order to use other fieldbuses an external fieldbus module and an ACS 400 DDCS adapter must be used, both are available as options. N2 fieldbus is also available as embedded fieldbus option for ACS 400V.

## Local control possibilities

1. Control from control panel: ACS 400V can be directly controlled from control panel without making any connections to the ACS 400V I/O. In this case motor starts and stops from control panel's START/ STOP button and required speed (Hz) is set with control panel.

2. Control with PC-tool DriveWindow Light: For set-up and control purposes the PC-tool DriveWindow Light is also available as an option. For using this tool ACS 400V has to be equipped with an optional ACS 140 RS 485/232 adapter.

Contact your local ABB supplier for more information on options.

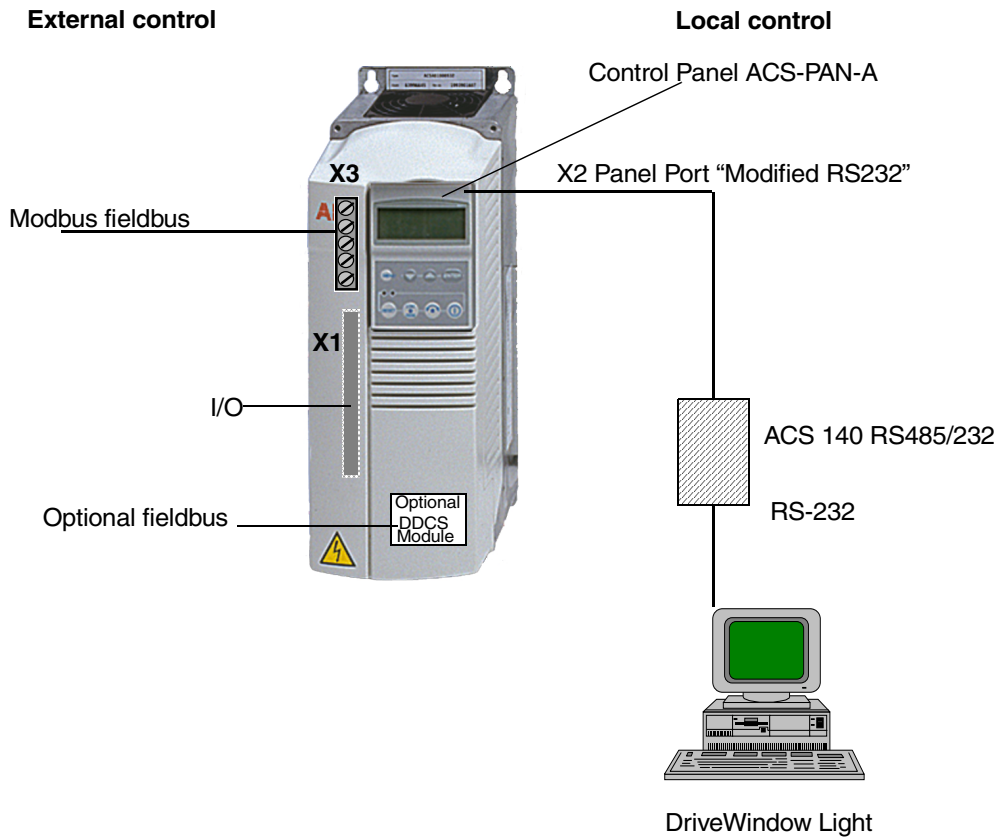

Figure 4 ACS 400V control locations.

# I/O Configuration

The following diagram summarizes the I/O connection alternatives given by the ACS 400V.

## Input signals

- Start/stop (DI1)
- Control signal 0 - 10 V(AI1)
- Actual value 0 - 10 V, eg. from pressure sensor (AI2)
- Activate to select PID control (DI2)
- Select setpoint1/setpoint2 (DI3)
- Constant speed 1 (DI4)
- Constant speed 2 (DI5)

## Output signals

- Analogue output AO: Frequency  
0 - 50 Hz  $\Leftrightarrow$  0- 20 mA
- Relay output 1: Fault  
-> 17 connected to 18
- Relay output 2: Running  
-> 20 connected to 22

## DIP switches, set to voltage signal positions

AI1: 0 - 10 V  
AI2: 0 - 10 V

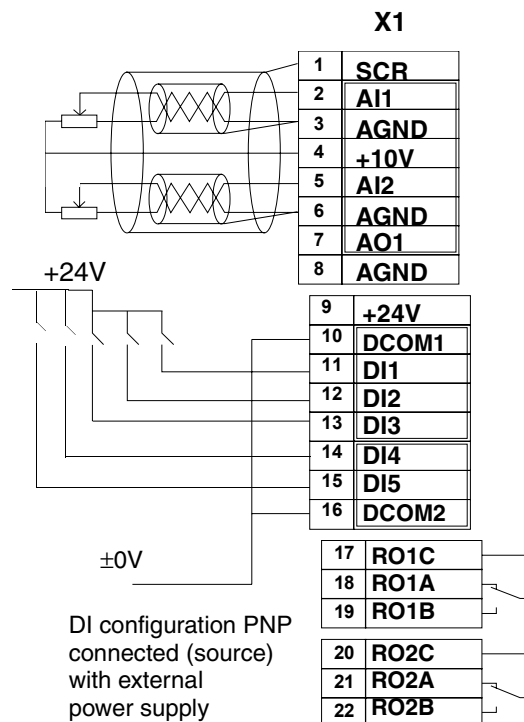
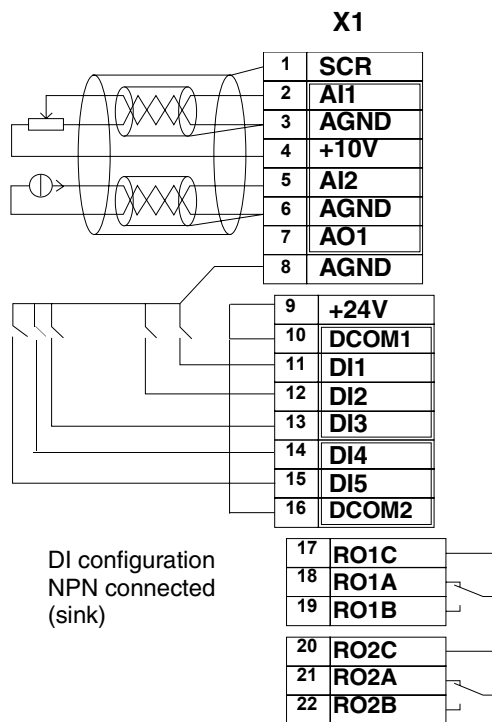
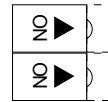
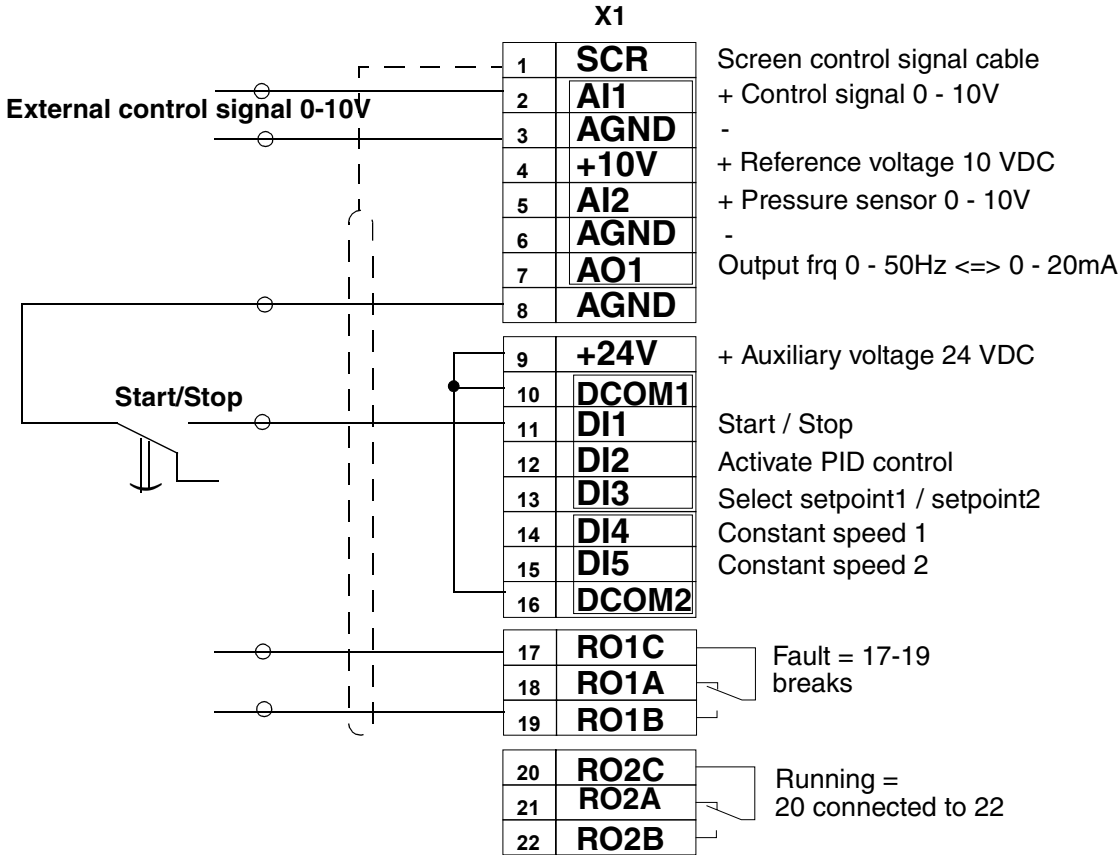
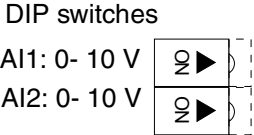

Figure 5 ACS 400V I/O connection.

# Alternative ACS 400V Operation Modes (Hardwire Connections)

## Start / Stop and External Control Signal 0-10 V

- Set DIP switches to voltage signal positions
- Start signal is given by activating DI1 (11)
- Control signal 0-10 VDC from external regulator is connected to AI1 (2, 3)
- Two constant speeds are possible, if 8, 14 and 8, 15 are connected using a switch between 14 and 15, see page 14



## Start / Stop with 1 Constant Speed

- Set DIP switches to voltage signal positions
- Motor starts by activating DI1 (11)
- One constant speed can be set
- Constant speed 1 is set with parameter 1202
- Constant speed 1 is selected with DI4 (14)

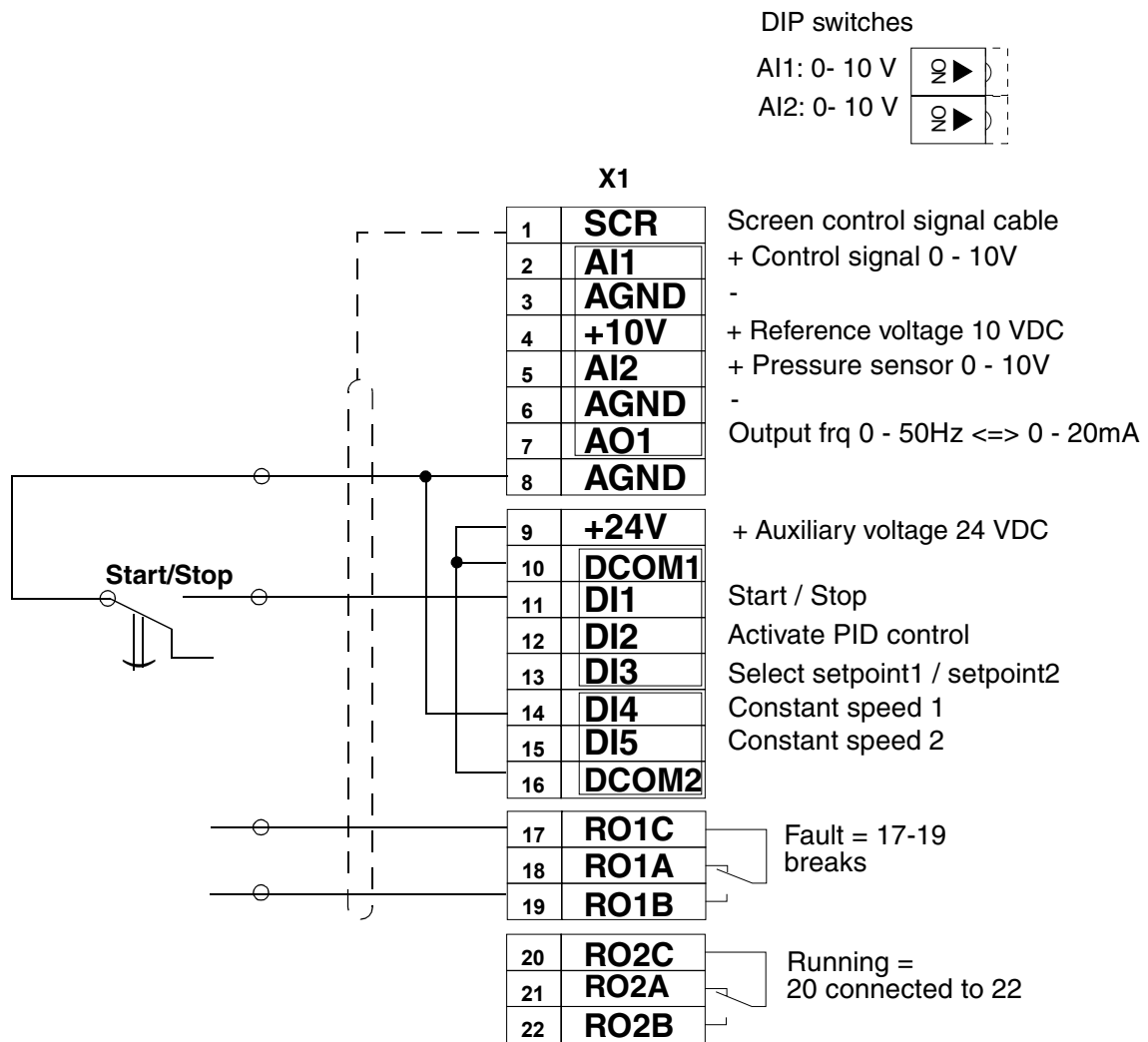

## Start / Stop with 2 Constant Speeds

- Set DIP switches to voltage signal positions
- Motor starts by activating DI1 (11)
- Two different constant speeds can be set
- Constant speed 1 is set with parameter 1202
- Constant speed 2 is set with parameter 1203
- Constant speed 1 is selected with DI4 (14)
- Constant speed 2 is selected with DI5 (15)

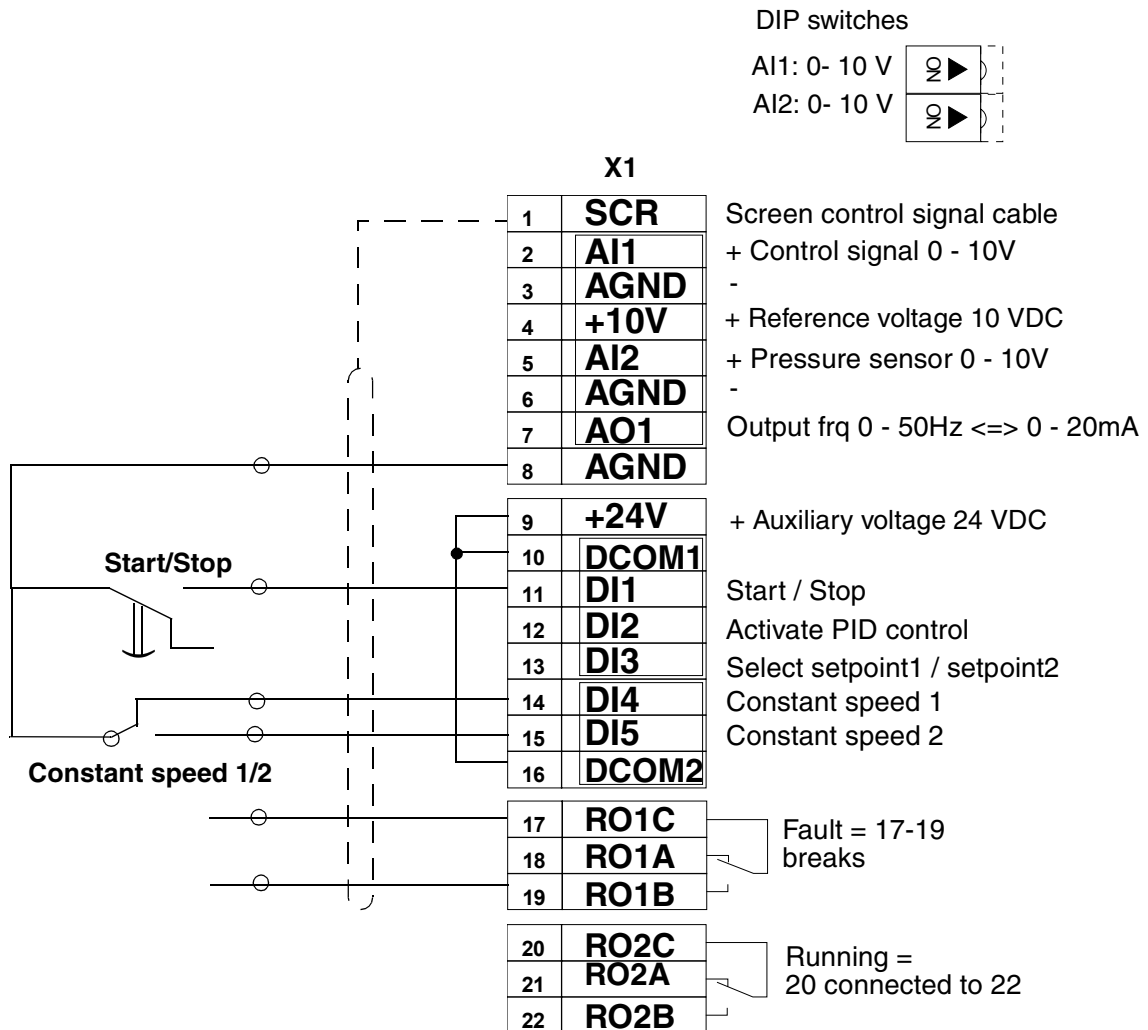

## PID Control with 1 Setpoint

- Set DIP switches to voltage signal positions
- Connect 8 and 12 together to activate PID Control (DI2 active)
- Motor starts when DI1 is activated (11)
- Reference value 1 is set with parameter 4020 (see Figure 6, page 21)
- Actual value (pressure sensor) is connected to AI2 (5,6)

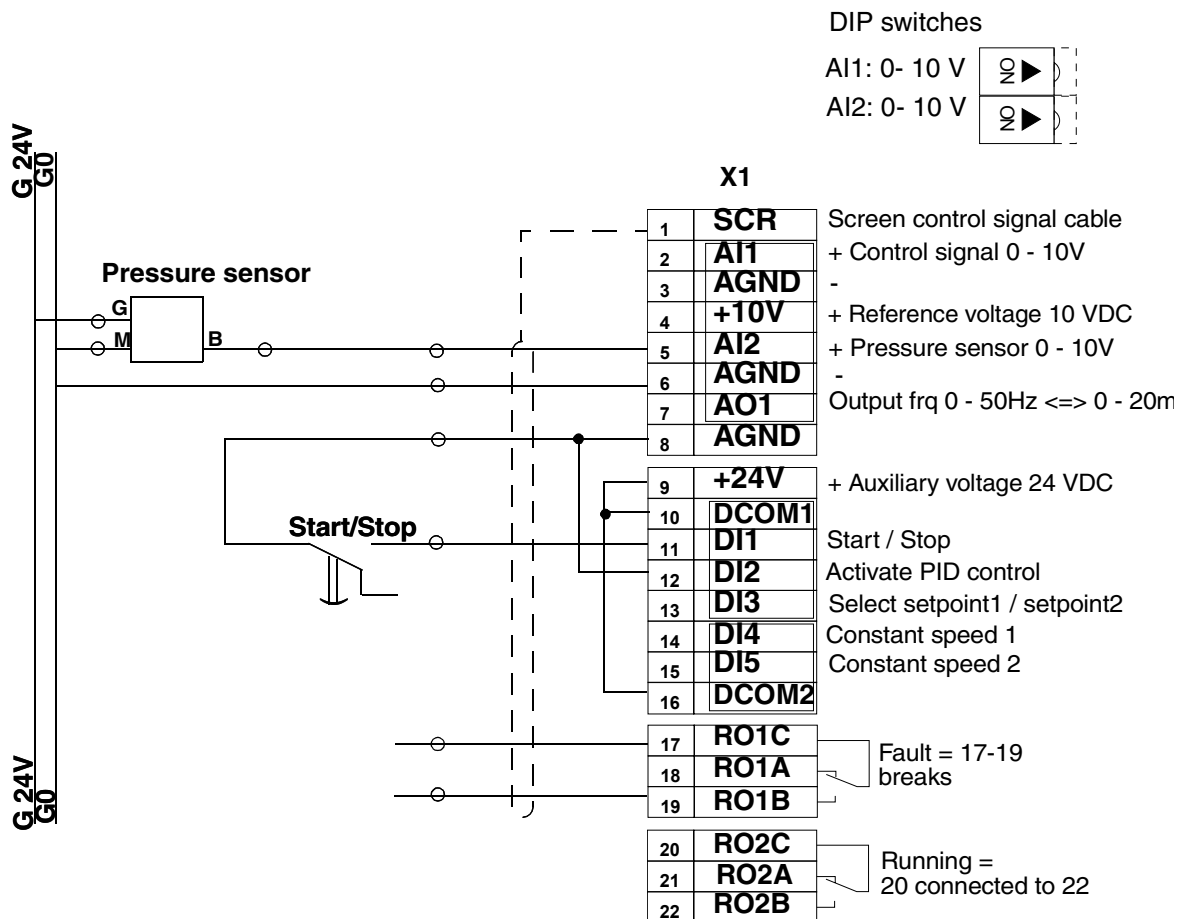

## PID Control with 2 Setpoints

- Set DIP switches to voltage signal positions
- Connect 8 and 12 together to activate PID Control (DI2 active)
- Motor starts when DI1 is activated (11)
- Select reference value 1 or 2 with DI3
- If DI3 is not active, reference is value 1. If DI3 is active the reference value is 2.
- Reference value 1 is set with parameter 4020 (see Figure 6, page 21)
- Reference value 2 is set with parameter 4120 (see Figure 6, page 21)
- Actual value (pressure sensor) is connected to AI2 (5, 6)

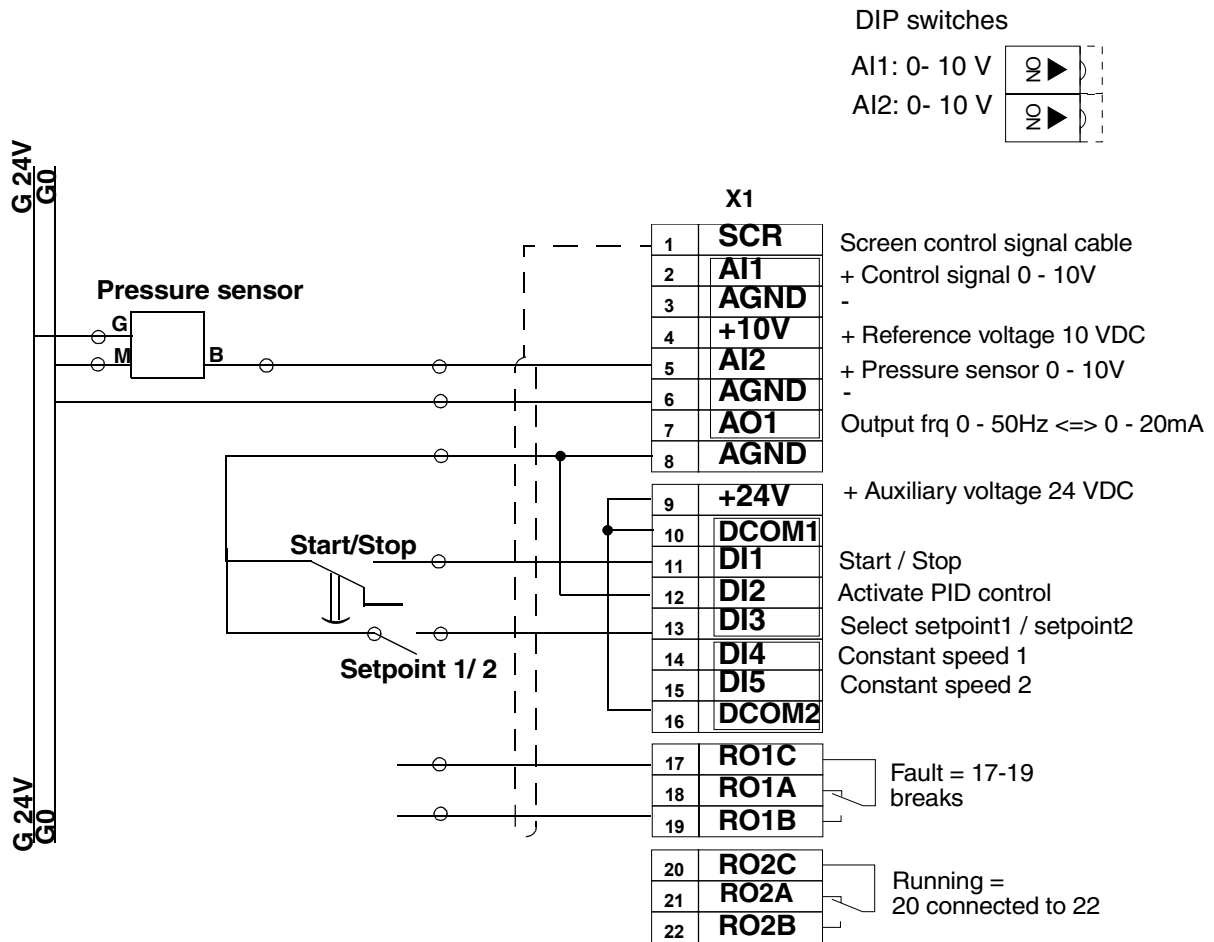

## Operating with ACS-PAN-A Control Panel

The ACS 400V is delivered with an ACS-PAN-A control panel, which is an alphanumeric control panel with LCD display and multiple languages. The control panel can be connected to and detached from the converter at any time. If the control panel is detached when the panel is in local mode, then the ACS 400V will trip and stop. If the panel is detached in remote mode, then the ACS 400V will continue operation as before. The panel can be used to copy parameters to other ACS 400V converters with the same software revision can be viewed from (parameter 3301).

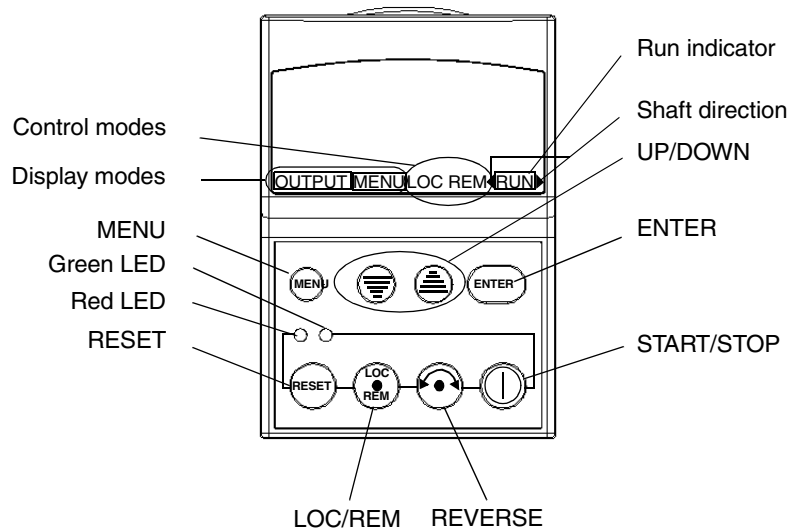

### Control Modes

The very first time the drive is powered up, it is controlled from the Control Terminal Block X1 (remote control, **REM**). The ACS 400V is controlled from the control panel when the drive is in local control (**LOC**).

Switch to local control (**LOC**) by pressing and holding the LOC/REM button until first LOCAL CONTROL or later LOCAL, KEEP RUN is displayed:

- If the button is released while LOCAL CONTROL is displayed, the panel frequency reference is set to the current external reference and the drive is stopped.
- When LOCAL, KEEP RUN is displayed, the current run/stop status and the frequency reference are copied from the user I/O.

Start and stop the drive by pressing the START/STOP button.

Change the shaft direction by pressing the REVERSE button (parameter 1003 must be set to REQUEST).

Switch back to remote control (**REM**) by pressing and holding the LOC/REM button until REMOTE CONTROL is displayed.

### Shaft Direction

RUN > < RUN	<ul style="list-style-type: none"> <li>• Drive is running and at setpoint</li> <li>• Shaft direction is forward (&gt;) or reverse (&lt;)</li> </ul>
RUN > (or < RUN) Arrow head blinking rapidly	Drive is running but not at setpoint.
> (or <) Arrow head blinking slowly	Drive is stopped.

## Actual Values in Output Display

When the control panel is powered up, the panel displays a selection of actual values. Whenever the MENU button is pressed and held, the control panel resumes this **OUTPUT** display.

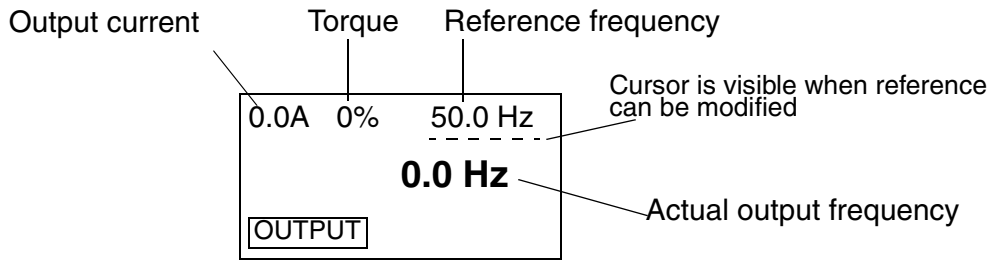

The frequency reference can be modified using UP/DOWN buttons when it is underlined. Pressing UP or DOWN buttons changes the reference immediately.

The reference can be modified in local control mode, but also in remote control mode if the ACS 400V is parameterised in such a way.

## Menu Structure

ACS 400V has a large number of parameters which are listed in menus. The so-called **basic parameters** are in the short menu. All the parameters are in full menu which is initially visible.

The menu consists of parameter groups and menu functions.

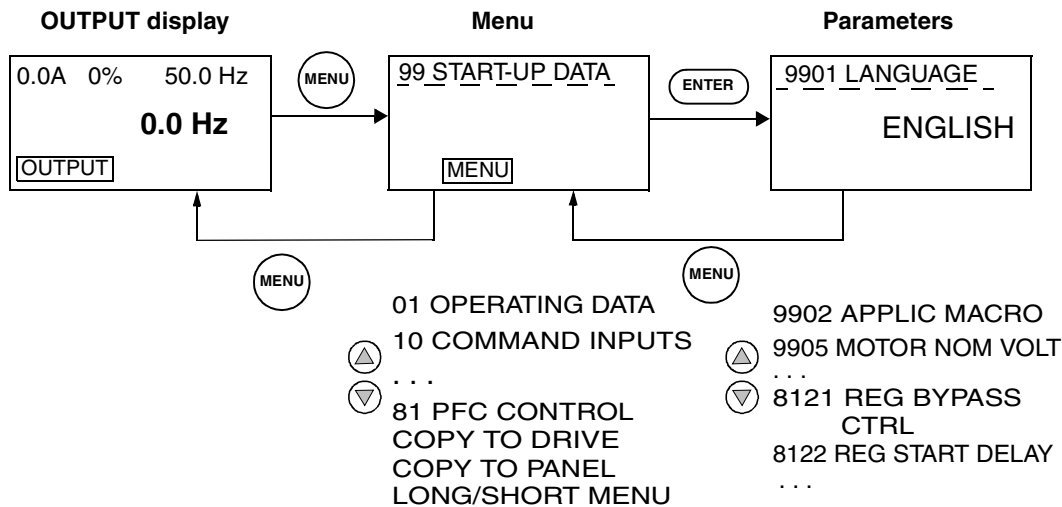

## Setting Parameter Value

Parameter value set mode is entered by pressing ENTER. In set mode, value is underlined. Value is altered by using UP/DOWN buttons. Modified value is stored by pressing ENTER. Modifications can be cancelled and set mode inactivated by pressing MENU.

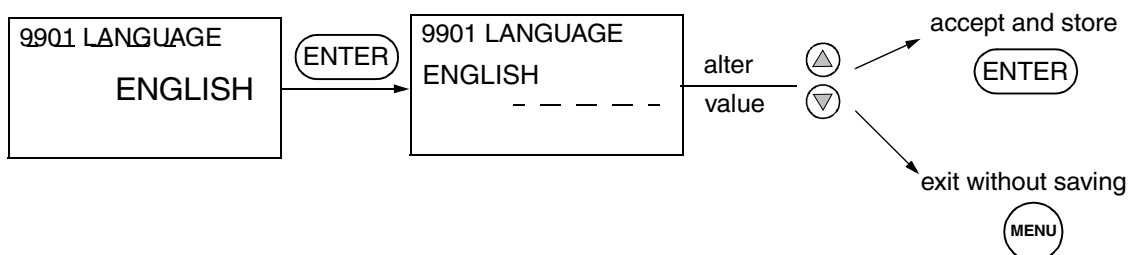

**Note!** In the parameter value set mode the cursor blinks, when the parameter value is altered.

**Note!** To view the parameter default value in the parameter value set mode, press the UP/DOWN buttons simultaneously.

### Changing Between Basic and Full Parameter Set

Press and hold ENTER button to change from basic parameter set to full parameter set. When full Menu is active, an asterisk appears on the second row of the panel display in Menu. Activate this function again to resume the short Menu.

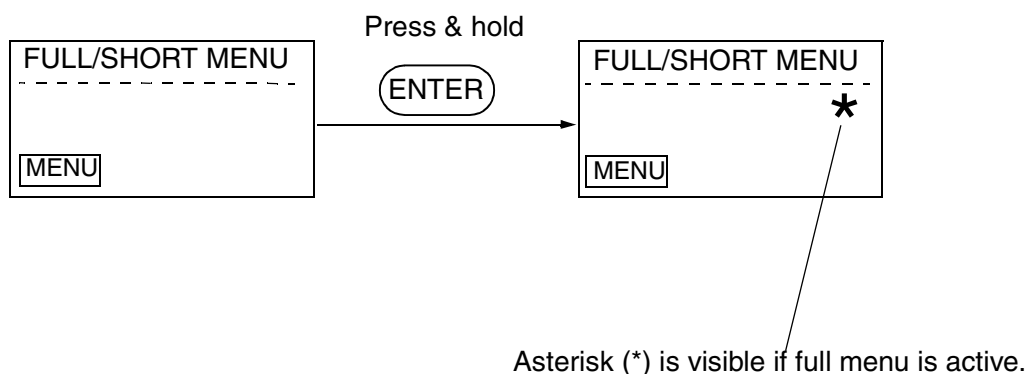

### Diagnostic displays

When the red LED of the ACS-PAN-A is on or blinking, a fault is active. The relevant fault message flashes in the panel display.

When the green LED of the ACS-PAN-A is blinking, an alarm is active. The relevant alarm message is shown in the panel display. Alarms 1-7 arise from button operation and green LED does not blink for them.

The alarm and fault messages disappear when MENU, ENTER or the arrow buttons of control panel are pressed. The message will reappear after a few seconds if the keypad is not touched and alarm or fault is still active. Refer to ACS 400 User's Manual Diagnostics section for complete list of alarms and faults.

### Resetting the Drive from the Control Panel

To reset a fault when the red LED is on, press the RESET button.

**Caution!** Resetting the fault may start the drive when in remote control.

To reset a fault when the red LED is blinking, turn the power off.

**Caution!** Turning the power on again may start the drive immediately.

### LED Indicators

Status of ACS 400V can be seen from the LED indicators in the control panel and if the control panel is removed in the unit enclosure.

Red LED	Green LED	
OFF	ON	Power ON and drive is operating normally.
OFF	BLINKS	Alarm is active.
ON	ON	Fault is active. Drive can be reset from the control panel.
BLINKS	ON	Fault is active. Turn power off to reset the drive.

## Parameterising ACS 400V

The parameters of ACS 400V are pre-set to enable operation according to every ACS 400V operation mode in HVAC applications. In commissioning the drive the user is however required to set a limited number of parameters according to the motor and application. The table below lists these and the pre-set HVAC parameter default values. Also all other parameters can be set with the help of ACS 400 User's Manual. Descriptions of parameters can be found in ACS 400 User's Manual.

Check that the full Menu is visible in the ACS 400V when starting parameterising. Go through, in the given order, all the parameters which are marked with an X in the Set column:

- First change the parameter 9902 APPLICATION MACRO to value 6 (PID CONTROL)
- Set the motor parameter.

After this the ACS 400V is ready for operation if connection is according to one of the five ACS 400V operation modes. If changes are needed to the values of relevant parameters in these connections, they can easily be changed with the help of the HVAC parameter table (Table 1) and PID regulator tables (Table 2 and Table 3).

Table 1 HVAC Parameter table.

Code	Name	Default	Set	User
9902	APPLIC MACRO	FACTORY (0), <b>change</b> this first to PID CONTROL	X	
9901	LANGUAGE	ENGLISH		
9905	MOTOR NOM VOLT	400 V	X	
9906	MOTOR NOM CURR	MOTOR CURRENT, SEE MOTOR RATING PLATE (A)	X	
9907	MOTOR NOM FREQ	50 Hz	X	
9908	MOTOR NOM SPEED	MOTOR SPEED, SEE MOTOR RATING PLATE	X	
9909	MOTOR NOM POWER	MOTOR POWER, SEE MOTOR RATING PLATE	X	
9910	MOTOR COS PHI	MOTOR COS PHI, SEE MOTOR RATING PLATE	X	
1001	EXT1 COMMANDS	DI1		
1002	EXT2 COMMANDS	DI1		
1102	EXT1/EXT2 SEL	DI2		
1103	EXT REF 1 SELECT	AI1		
1106	EXT REF 2 SELECT	AI1		
1201	CONST SPEED SEL	DI4, 5		
1202	CONST SPEED 1	5 Hz (CONSTANT SPEED 1 IN Hz)		
1203	CONST SPEED 2	10 Hz (CONSTANT SPEED 2 IN Hz)		
1601	RUN ENABLE	NOT SEL		
2003	MAX CURRENT	1.1* MOTOR NOMINAL POWER (A), SEE MOTOR RATING PLATE	X	
2006	UNDERVOLT CTRL	ENABLE (TIME)		
2008	MAXIMUM FREQ	50 Hz (DEPENDS ON THE MOTOR SIZE, CHECK ALSO YOUR APPLICATION)	X	
2107	START INHIBIT	ON		
2202	ACCELER TIME 1	10		
2203	DECELER TIME 1	10		
2606	U/F RATIO	SQUARE		
3101	NR OF TRIALS	5		
3106	AR UNDER VOLTAGE	ENABLE		

The following parameters are needed with pressure or flow control (operation modes PID control with 1 setpoint and PID control with 2 setpoints). The diagrams below are an example how to choose the value for internal setpoint (parameters 4020 and 4120). For more detailed information on parameters, refer to ACS 400 User's Manual, Complete Parameter List, Group 40: PID Control and Group 41: PID Control (2).

Table 2 PID regulator 1.

Code	Name	Default	Set	User
4001	PID GAIN	0.7 (PID GAIN FACTOR)		
4002	PID INTEG TIME	10 (PID INTEGRATION TIME)		
4003	PID DERIV TIME	0 s		
4004	PID DERIV FILTER	0 s		
4016	PID PARAM SET	D13		
4019	SET POINT SEL	INTERNAL		
4020	INTERNAL SETPNT	50 % (SETPOINT 1 IN %, SEE DIAGRAM BELOW)		

Table 3 PID regulator 2.

Code	Name	Default	Set	User
4101	PID GAIN	0.7 (PID GAIN FACTOR)		
4102	PID INTEG TIME	10 (PID INTEGRATION TIME)		
4103	PID DERIV TIME	0 s		
4104	PID DERIV FILTER	0 s		
4119	SET POINT SEL	INTERNAL		
4120	INTERNAL SETPNT	100 % (SETPOINT 2 IN %, SEE DIAGRAM BELOW)		

Figure 6 Reference value (%) selection from the setpoint.

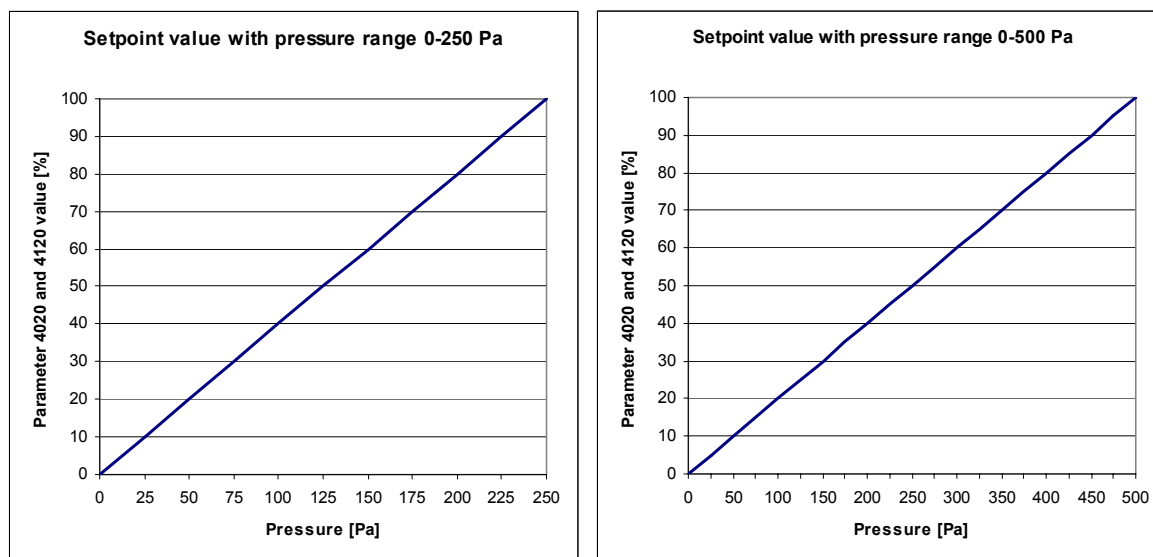

### Using Other Features of ACS 400V

With ACS 400V the user can also take advantage of the standard ACS 400 frequency converter features. All the standard ACS 400 functionality is available.

The parameter default values of the ACS 400V differ from the default values of the standard ACS 400 drive in some points. The ACS 400V parameter values can be manually changed to any other value.

**Note!** If some another macro from ACS 400 User's Manual is used, the parameter values need to be manually changed. Changing parameter 9902 APPLICATION MACRO will always cause the ACS 400V to show ACS 400V specific default values for parameters specified in tables 1, 2 and 3.

## Appendix 1:

### Electro Magnetic Compatibility EMC

The ACS 400V unit is delivered with a RFI filter. The RFI filter must be used in order to comply with **EN61800-3, First Environment, Restricted Distribution, and AS/NZS 2064, 1997, Class A** requirements.

The motor cable lengths have to be limited as specified in the table below and the cable must have effective screen. At the motor end, the cable screen must be earthed 360 degrees with an EMC cable gland (e.g. Zemrex SCG screened cable glands). For more detailed cabling instructions refer to the ACS 400 User's Manual Appendix C.

Table 4 Maximum motor cable lengths with input filters ACS400-IF11-3... ACS400-IF41-3 and switching frequency 4 kHz or 8 kHz.

Converter Type	Filter	Switching Frequency	
		4 kHz	8 kHz
ACS 401-V004-3-x	ACS400-IF11-3	100 m	-
ACS 401-V005-3-x	ACS400-IF11-3	100 m	-
ACS 401-V006-3-x	ACS400-IF11-3	100 m	-
ACS 401-V009-3-x	ACS400-IF21-3	100 m	100 m
ACS 401-V011-3-x	ACS400-IF21-3	100 m	100 m
ACS 401-V016-3-x	ACS400-IF31-3	100 m	100 m
ACS 401-V020-3-x	ACS400-IF31-3	100 m	100 m
ACS 401-V025-3-x	ACS400-IF41-3	100 m	100 m
ACS 401-V030-3-x	ACS400-IF41-3	100 m	100 m
ACS 401-V041-3-x	ACS400-IF41-3	100 m	100 m

Conducted emission with input filters ACS400-IF11-3 and ACS400-IF21-3 complies with the limits for unrestricted distribution class in First Environment as specified in EN61800-3 (EN50081-1) provided that maximum motor cable length is 30 m and switching frequency 4 kHz.

### Distribution Networks Isolated from Earth

Input filters designed for ACS 400V cannot be used in an isolated, or high impedance earthed industrial distribution networks.

### Line current harmonics

The standard EN 61800-3 refers to EN 61000-3-2 which specifies limits for harmonic current emissions for equipment intended to be connected to public low-voltage distribution systems.

### Low-Voltage Public Supply Network

The limits and requirements of the EN 61000-3-2 apply for equipment with rated current  $\leq 16A$ . The ACS 400V is a professional equipment to be used in trades, professions or industries and which is not intended for sale to the general public. Therefore the ACS 400V with a total rated power greater than 1kW conforms with EN 61000-3-2.

## **Industrial Networks**

If ACS 400V is used in an industrial installation for which the EN 61000-3-2 is not relevant, a reasonable economical approach which considers the total installation shall be used.

Typically a single low power equipment like ACS 400V does not cause a significant voltage distortion to network. However, the user shall be aware of the values of the harmonics currents and voltages occurring within the power supply system before connecting the ACS 400V, as well as the internal impedance of the supply system. The current harmonic levels of the ACS 400V under rated load conditions are available on request and the assessment procedure given in appendix B of the EN 61800-3 may be used as a guide.







3AFE 64648900 REV B  
EN

Effective: 2.9.2002  
© 2002 ABB Oy

Subject to change without prior notice.

---

ABB Oy  
BAU Drives  
P.O. Box 184  
00381 Helsinki  
FINLAND  
Telephone +358-10-2211  
Telefax +358-10-222 2681